

# User Manual

## Explosion-safe signal lights Type series AR-077



II 2 G Ex d IIC T6  
II 2 G Ex de IIC T6  
II 2 D Ex tD A21 IP65 T 80 °C

EC Type Certificate No. KEMA 07ATEX0046

### XENON FLASHING SIGNAL LIGHT



With  
factory sealed  
cable Ex d



With  
connection terminals  
Ex de

### LED STATUS LIGHT



With  
factory sealed  
cable Ex d



With  
cable gland &  
terminals Ex de



## 1. Safety Instructions

The signal light AR-077 is an explosion-safe product suitable for use in hazardous areas with explosion hazard from flammable gases, vapors, mist and dust, classified as Zone 1, Zone 2, Zone 21 or Zone 22.

This manual must be read and understood for safe use of the signal lights whereby all warnings and instructions must be followed.

- Installation may only be carried out by personnel trained and qualified in explosion safety taking into consideration the instructions mentioned on the equipment and in this manual. Besides that, local regulations that apply to the installation must be followed.
- Only connect this equipment to the voltage and the type of voltage for which it is designed.
- Before electrical installation isolate the electrical power to the signal light.
- The transparent dome may be sensitive for electrostatic loading therefore only use a damp cloth to clean the dome. Do not use solvents.
- For the signal light model with connection terminals only use certified cable glands and blind plugs that are suitable for the specific use. For example II 2G Ex e IIC for gas explosion hazard and II 2D Ex tD A21 IP65 for dust explosion hazard.
- Either decommission the signal light or do not use it when it is damaged.
- During installation of the signal light national safety regulations must be observed.
- Only use the signal light under the environmental conditions for which it is specified. Deviated environmental conditions can contribute to damage to the equipment and may lead to possible danger to the life of the user.
- Do not use the signal light at a temperature deviating from the ambient temperature range specified.
- Follow all instructions as attached to the equipment and as mentioned in this manual.
- The signal light may not be opened in hazardous classified locations unless the environment has been known to be non-hazardous.
- Repairs may only be carried out by the manufacturer or by a person appointed by the manufacturer.
- Modifications to the equipment or changes to the design are not permitted.
- The product may only be used for the function for which it is designed and shall be maintained in a good and clean condition.

If these instructions are not followed the explosion safety of the equipment cannot be guaranteed. The equipment could then endanger the life of the user and could cause the ignition of an explosive atmosphere. Consequently, Artidor as the manufacturer will waive any responsibility.

## 2. Description

The explosion-safe signal lights AR-077 have been designed to attract attention in a safe manner in environments where explosion hazards may exist. For example to indicate a telephone call, indicating the status of a machine or report a malfunction or hazard that requires immediate action.

The signal light comprises a metal housing with a transparent dome covering the light source. This can be a flashing or continuous light source. The interior of the transparent dome has light dispersing ribs to contribute attention of the light beam.

The explosion safety to gas is arranged by the application of protection degree against ignition 'Flameproof enclosure' in addition to the model with connection terminals protection degree 'increased safety' has been applied. The explosion safety to dust is arranged by the application of protection degree against ignition 'protection by enclosure'.

The dome is made out of high quality polycarbonate with an exceptionally high impact resistance of more than 7 Nm. Therefore the dome is not equipped with an extra guard.

The signal lights can be supplied in various models, differing with respect to:

- a. the light source;
- b. the light color;
- c. the voltage;
- d. the material of the armature;
- e. the type of electrical connection.

Each of these options are explained in more detail further in this document.

The specific model is identified by the model code. See the table below.

## AR-077/211/XE-230V

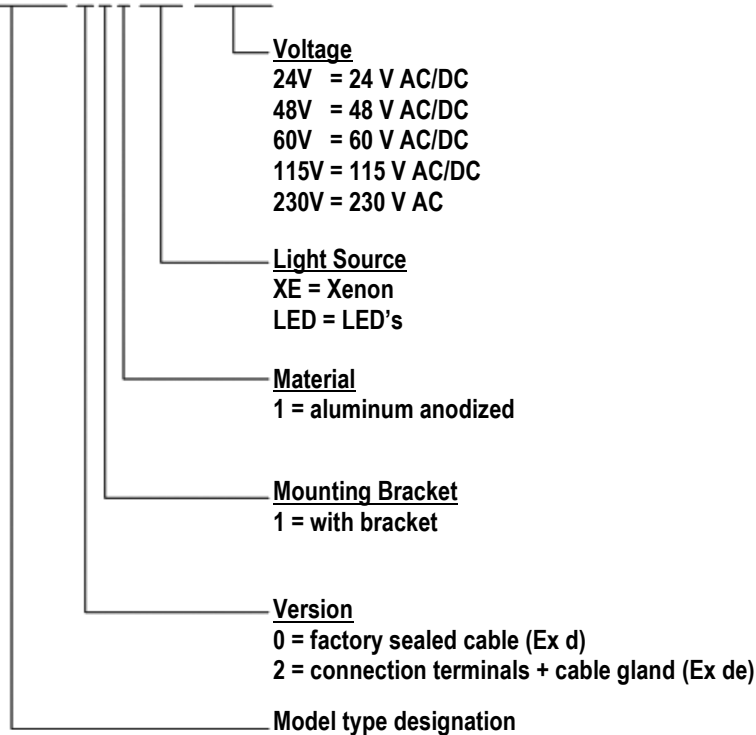

### a. Light source

The signal light can be supplied in two different basic types: Strobe Flashing or Steady Burn each with their own specific type of light source as described below.

#### **Xenon lamp (flashing light)**

The strobe flashing light contains an electronic printed circuit board with a xenon gas filled lamp. When operating it produces bright flashes of light with the energy of 5 Joules at a frequency of approximately 60 flashes per minute. The printed circuit board has a small potentiometer with which the flash frequency can be changed within the range of approximately 50 to 80 flashes per minute.

#### **Multi-LED reflex lamp (steady burn or blinking status light)**

The steady burn or blinking status light contains electronics with a multi-LED reflex lamp.

### b. Light color

The color of the Xenon flashing light is obtained by inserting a color-fast lens. In case of the Multi-LED reflex lamp, the color is created by using colored LED's. In both cases a stable color is obtained.

### c. Supply voltage

With regard to the voltage from the power supply the signal can be supplied for the following voltages. All the other electrical data is also given in the table.

Flashing signal light (Xenon)					
Voltages	230 V	115 V	60 V	48 V	24 V
Min / max	200...245 V	95...120 V	44...62 V	44...62 V	20...27 V
Current	65 mA	130 mA	170 mA	170 mA	300 mA
Frequency	50...60 Hz	0...60 Hz	0...60 Hz	0 ...60 Hz	0...60 Hz
Power	15 VA	15 VA	10 VA	10 VA	8 VA

Status light (LED)			
Voltages	230 V	24 V	Other voltages on request
Variation	200...245 V	20...27 V	
Current	5 mA	30 mA	
Frequency	50 / 60 Hz	0...60 Hz	
Power	0,8 VA	0,7 VA	

**d. Material**

The housing is manufactured from aluminum in the colors gray and red. The anodized surface finish provides excellent protection against chemicals and seawater.

**e. Type of electrical connection**

With regard to the electrical connection the signal light can be ordered with one of the two provisions described below.

**Factory sealed cable (Ex d - version)**

The cable version of the signal light has been equipped with a factory sealed cable as fixed cable entry device into the flameproof housing. The standard length of the cable is 3 m but a longer cable can be supplied on request.

**Cable gland and connection terminals (Ex de - version)**

This version of the signal light has been provided with a connection compartment containing connection terminals. The connection compartment is separated from the flameproof compartment. To the connection compartment protection degree against ignition Increased Safety has been applied. It contains two threaded entries (M20 x 1.5). An Ex e certified cable gland and an Ex e blind plug are supplied for this as standard.

The metallic cable gland supplied requires the appliance of a fixed installed connection cable. The external connection cable must be installed in such a way that it cannot be pulled out of the gland (e.g. by use of a cable strain relieve device).

The signal light with connection terminals is supplied as standard with three connection terminals, however if through-wiring of multiple signal lights or a similar function is desired it can be ordered with six connection terminals. In this case, the signal light will be provided with a second cable gland.

### 3. Characteristics

The characteristics can be summarized as follows;

- Robust signal light with an attractive, elegant design;
- Obtainable as strobe flashing light or as steady burn status light;
- Equipped with a factory sealed cable or with a cable gland & connection terminals;
- Manufactured out of aluminum (anodized);
- Obtainable in six colored lights enabled by colorfast insert lenses;
- Manufactured on the basis of the European Directives including the ATEX directive;
- Suitable for use in gas and dust hazardous areas Zones 1 & 2 and Zones 21 & 22;
- Explosion safety category II 2GD and protection degree against ignition applied:  
Ex d IIC T6 or Ex de IIC T6 and Ex tD A21 IP65 T 80°C;
- Sealed against water and dust IP65;
- Suitable for internal and external use;
- Mounting position 360°.

### 4. CE - Marking

The signal lights comply to the European CE Directives for EMC and ATEX and therefore implicitly to the Low voltage Directive.

With regard to explosion safety the signal lights have been designed and manufactured on the basis of the essential safety requirements of European directive 2014/34/EU (ATEX 114) relating to Group II Category 2GD. Harmonized European construction standards have been applied fulfilling the essential requirements of these directives. For more details refer to section 6 Technical data and to the Declaration of Conformity as shown on the last page of this manual.

### 5. Application

The explosion-safe signal lights have been designed for and are suitable for use in hazardous classified areas due to flammable gases, vapors, mist, fibers and dust. Because they are explosion-safe and certified on the basis of Group II Category 2 GD of the ATEX Directive they are suitable for use in the hazardous areas classified as follows:

- for combustible gases, vapors and mist: Zone 1 and Zone 2
- for combustible fibers and dust: Zone 21 and Zone 22.

The parts used are all manufactured from corrosion resistant materials and are therefore resistant to the effects of most common chemicals. If use in special environmental conditions is required, please contact the manufacturer Artidor Explosion Safety B.V.

## 6. Technical Data

Explosion safety category:	ATEX II 2GD
Protection against ignition:	Ex d IIC T6, Ex tD A21 IP65 T80°C (cable version) Ex de IIC T6, Ex tD A21 IP65 T80°C (cable gland version)
Conformity:	2014/34/EU (ATEX 114) and 2014/30/EU (EMC)
Standards applied:	EN 60079-0:2006, EN 60079-1:2004, EN 60079-7:2003, EN 61241-0:2006, EN 61241-1:2004 EN 50081-1 and EN-50082-1
EC Type Examination Certificate:	KEMA 07ATEX0046
Ambient temperature:	-20 °C to +40 °C
Ingress Protection level:	IP65 according to EN 60529
Material housing:	Anodized aluminum, colors grey and red
Material transparent dome:	Polycarbonate, impact-resistance > 7 Nm
Material mounting bracket:	Stainless steel, uncoated
Light source (Xenon)	Xenon bulb, 5 Joule, 1 flash / sec, (8·10 <sup>6</sup> flashes lifetime)
Light source (LED):	Multi-LED reflex lamp
Lens colors:	Red, orange, yellow, green, blue and clear
Mounting position:	As desired (360°)
Activation time:	100%
Circumstances of use:	Exterior and interior use
Entries AR-077/011:	Factory sealed cable, color coded, 3 x 1 mm <sup>2</sup> , length 3 meters
Entries AR-077/211:	M20 x 1.5 (2x), cable gland Ø 6-12 mm (1x) and blind plug (1x)
Connection terminals:	3 x 2.5 mm <sup>2</sup>
Earth connection:	External, stainless steel, 4 mm <sup>2</sup>
Weight:	1,170 gram (AR-077/011/...) 1,610 gram (AR-077/211/...)

## 7. Dimensions

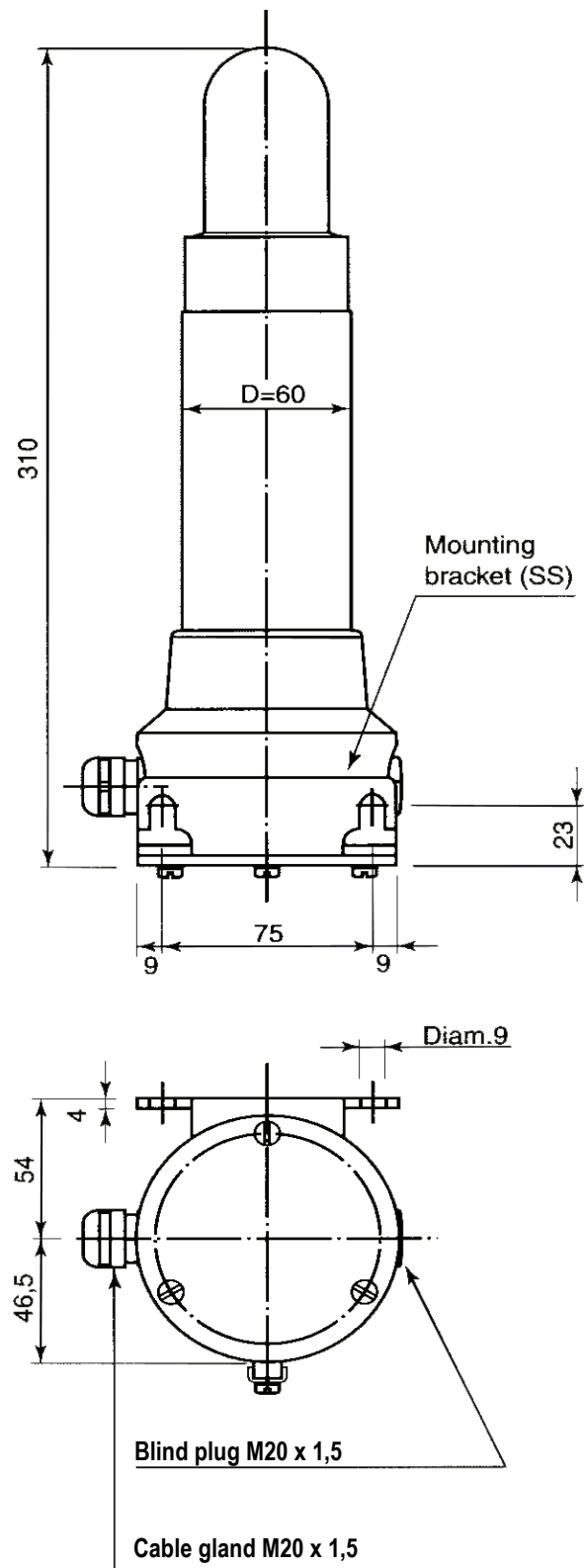



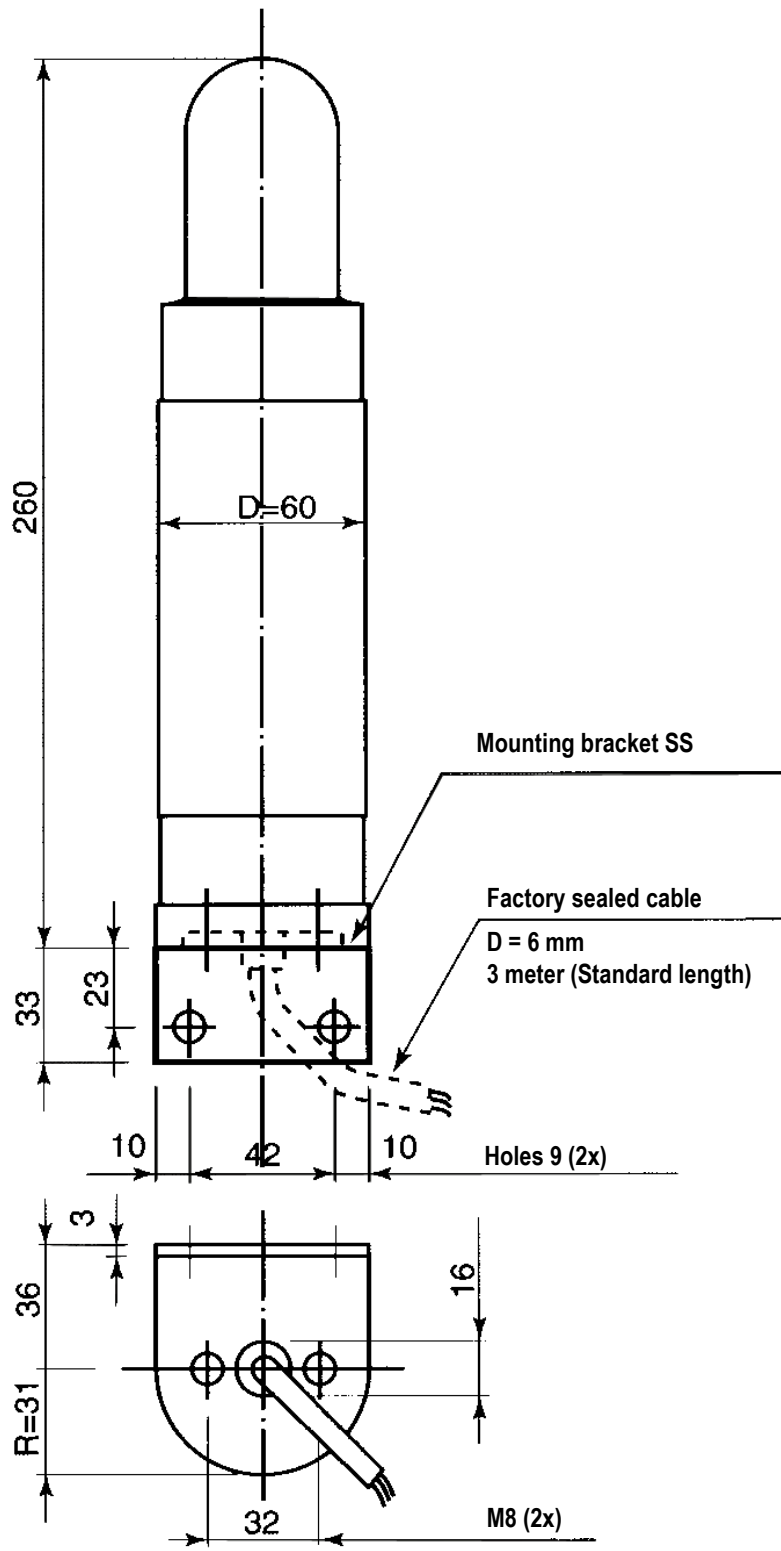



## 9. Installation instructions

### General

- Installation of explosion-safe equipment must be carried out by personnel specially trained and qualified to do this following the relevant requirements of the installation standard EN 60079-14.
- For the installation and use of this product the relevant safety regulations and the generally recognized latest state of the technology apply. Follow the national regulations and legal requirements.
- Take care that the framework, screws and mounting surface are strong enough to take the weight of the signal light.
- The general arrangement and mounting sizes are given in the drawing above.
- The supplied wall mounting brackets must be installed according the dimensional drawing above.
- Isolate electrical power prior to installation.

### For the model "with factory sealed cable"

- Follow the instructions as stated under the previous heading 'General'.
- The signal light with factory sealed cable is suitable for wall-mounting by using the wall mounting bracket. The light is also suitable for mounting on a flat surface in which case the mounting bracket will not be used.
- Connect an earth wire to the external earth boss and ensure that it is sufficiently connected to ground.
- Install the connection cable and make sure that it is protected from mechanical and chemical influences.
- Connect the end of the cable in a proper way to an external connection box and ensure this is done professionally. The connection box is not supplied. When a connection box is selected, make sure that it is suitably protected for the (explosion hazard) classification of the surroundings in which it will be used.
- The connection cable for the 230 V AC version has three wires for the following connections:

- Brown: Phase
- Blue: Neutral
- Green / Yellow: Ground

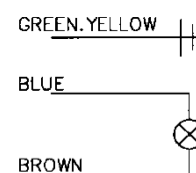

The 24, 48, 60 and 115 V AC/DC versions have a different cable with the following color coding:

- Black (1): Phase or (+)
- Black (2): Neutral or (-)
- Green / Yellow: Ground

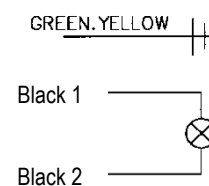

### For the model "with cable gland & terminals"

- Follow the instructions as stated under the previous heading 'General'.
- The signal light with cable gland & terminals is suitable for wall-mounting by using the bracket. It is also suitable for assembly using a pipe clamp across the cylindrical part (D=60) of the housing. In that case, remove the mounting bracket and reverse the cover of the connection compartment along with its cover screws.
- Ensure that the cable gland fits the individual cable used with respect to clamping size and type of cable. If not, apply a suitable cable gland and make sure that it is approved for its application.
- Connect an external earth wire to the earth boss and make sure that it is sufficiently connected to ground.
- The electrical power supply must be connected to (L) and (N) terminals in the connection compartment. If a direct current power supply is used, reverse polarity of the power supply will not affect the function or the safety of the signal light.
- Additionally, an earth wire must be connected to the PE connection terminal, see the wiring diagram below.
- Remove the external insulation from the cable over a length of 150 mm.
- Feed the cable into the connection compartment and fix the cable gland into place.
- Connect the connection wires following the instructions as given in this manual in chapter (14) "Instructions for connecting to the Ex e connection terminals".
- Tighten all screws of all connection terminals and close the cover.

### Electrical connection of the terminals

#### **NOTE**

For the 4-pole model (linking function), a 16 Amps limit of the transit current applies.

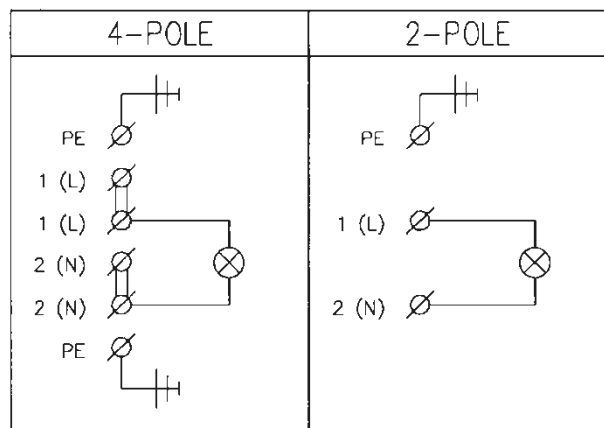

## 10. Opening the housing

### Compartment with lamp and electronics

The part of the housing that contains the lamp and the electronics is designed as flameproof Ex d and contains no components that need direct access. It is therefore not accessible to the user. The housing is

locked against unintentional opening and may only be opened under non-hazardous safe conditions. To do this follow the instructions as described under the heading 'Repair'.

### **Connection compartment with terminals (Ex de version)**

The compartment that contains the connection terminals is accessible to the user by unscrewing the three cover screws. Opening is only permitted when the power supply has been switched off and the area is known to be non-hazardous.

## **11. Maintenance**

For maintenance of the AR-077 signal lights the requirements as stated in EN 60079-17 apply. If the signal light and the connection cable are no longer in good condition or are very dirty or damaged they must be immediately repaired or cleaned.

The power supply to the signal lights must be switched off and may only be restored after the maintenance has been carried out and approved.

The advised maintenance cycle for these signal lights depends on their specific use and must therefore be agreed with the user for the expected use.

## **12. Repair**

Repair of the AR-077 signal lights may only be executed by applying original parts and may only be carried out by qualified workers who have been trained in accordance with EN 60079-19. Applying of non-original parts may lead to injury to persons and damage to the equipment.

If non-original parts are used or if repairs are carried out in an incompetent manner, the explosion-safety of the signal light can no longer be guaranteed. Therefore it is preferred that the signal light is returned to the manufacturer for repair.

If the housing is opened care must be taken of the following (also refer to the next drawing):

- The housing may not be opened unless the area is known to be non-hazardous.
- The armature must be disassembled in a logical sequence.
- The Ex d cover (foot) of the flameproof Ex d compartment is secured by a special locking screw mounted in the flange of the cover. The Ex d cover is directly mounted to the Ex d housing. The locking is arranged by using a cup point screw with internal 2 mm hexagon provision. Its function is twofold; primary preventing unwanted opening of the housing and secondary establishing a bonding mass connection between housing body and foot.
- The locking screw is inserted through the foot (Ex d cover) which is screwed directly into the housing. The locking screw is a notching screw with a hexagon socket with 2 mm between the flats.

- Make sure that the locking screw has been unscrewed before unscrewing the housing from the foot. In reverse, it is important that the locking screw is tightened after the housing has been screwed back on the foot sufficiently.
- Prior to screwing the foot into the housing, acid free grease must be applied to the thread preventing seizing of the threaded surfaces.

### Detail of the locking device

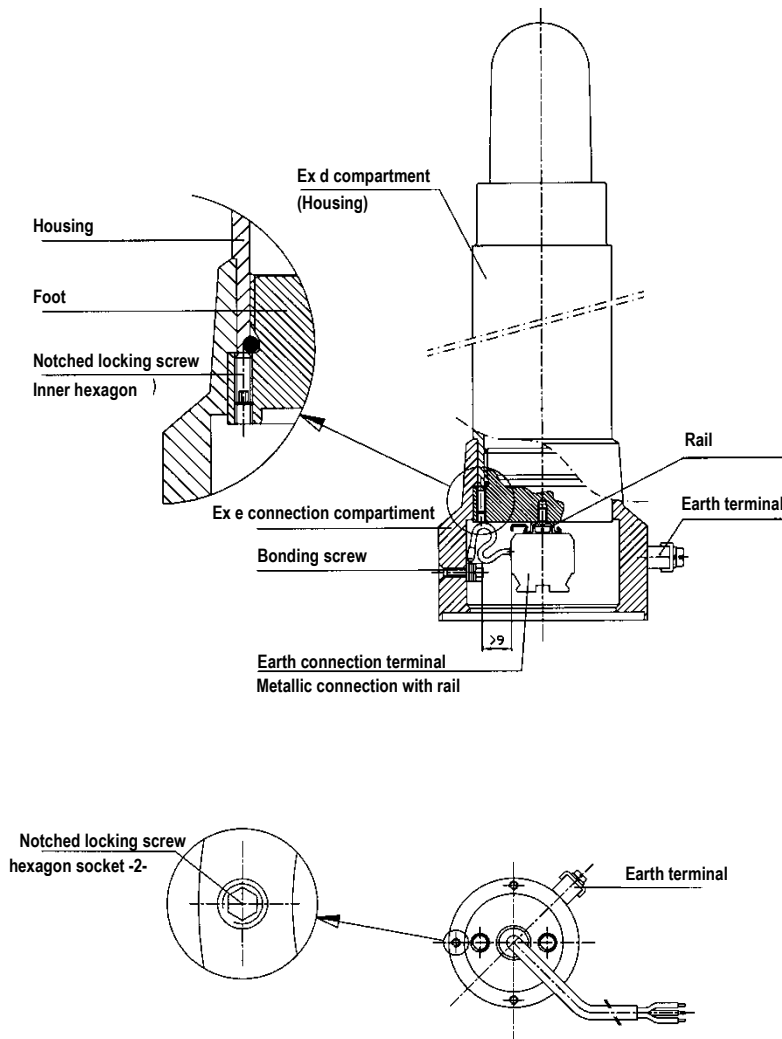

### 13. Removal / re-use

The equipment can be completely processed as electronic waste. For processing as disposal or reuse of the product and its packaging, national disposal and environmental laws and legislation must be taken into consideration.

## 14. Instructions for connection of the Ex e connection terminals

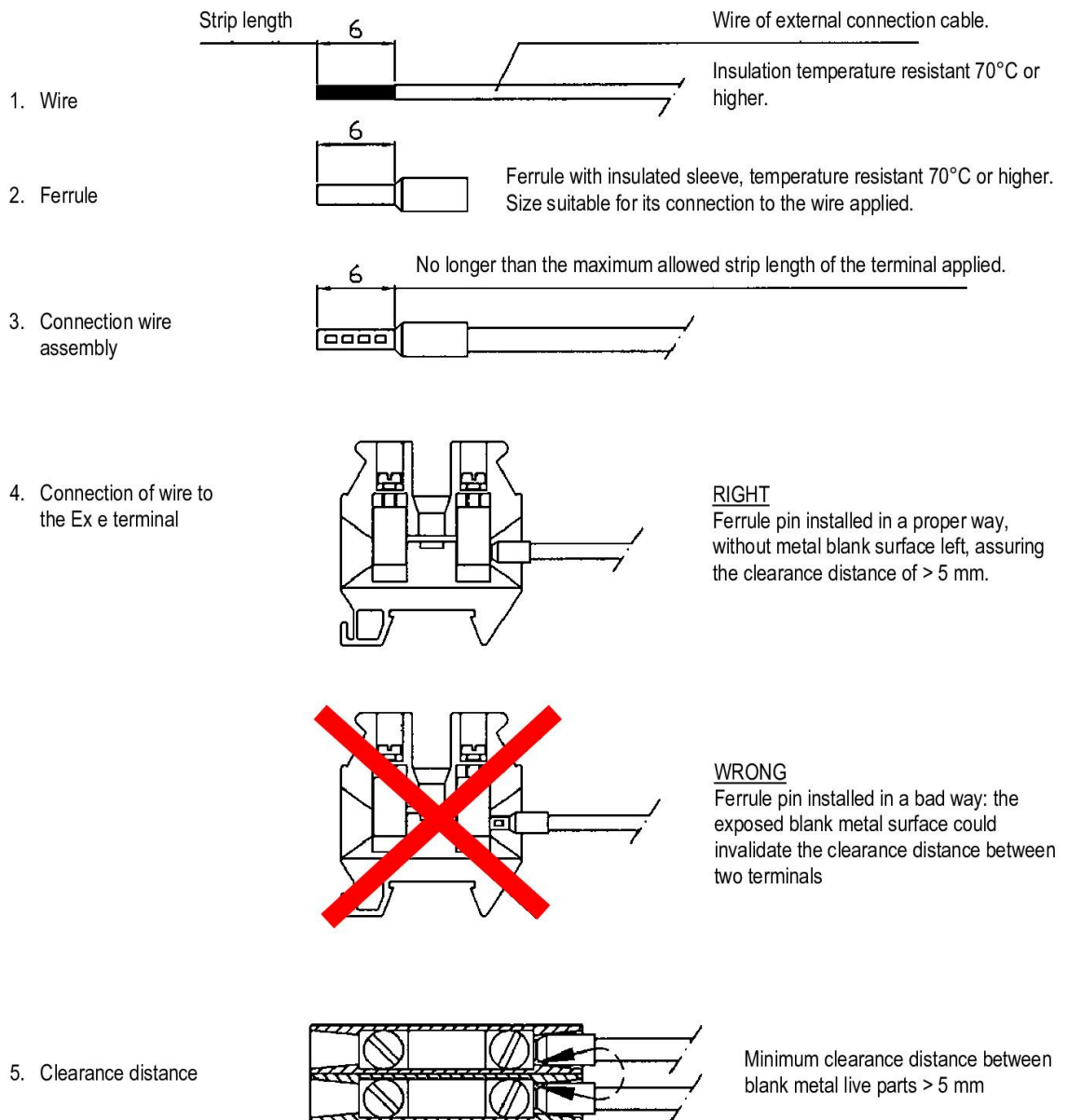

# EU Declaration of Conformity

We

ARTIDOR Explosion Safety B.V., Emopad 38, 5663 PB Geldrop, The Netherlands

herewith declare that the explosion-safe Signal Lights type series

**AR-077/.../XE & AR-077/.../LED**

**CE** 0063  II 2 G Ex d IIC T6, II 2 D Ex tD A21 IP65 T80°C

or

**CE** 0063  II 2 G Ex de IIC T6, II 2 D Ex tD A21 IP65 T80°C

covered by EC-Type Examination Certificate No. KEMA 07ATEX0046 issued by Dekra Certification B.V.,  
Notified Body identification No. 0344, Meander 1051, 6825 MJ Arnhem, The Netherlands and produced under  
Product Quality Assurance Notification KIWA 17ATEXQ0049, issued by Kiwa Nederland B.V.,  
Notified Body identification No. 0063, Wilmershof 50, 7327 AC Apeldoorn, The Netherlands

is in conformity with the provisions of the following European directives, including the latest amendments and with national legislation implementing this directive:

2014/30/EU  
Concerning electromagnetic Compatibility

2014/34/EU  
Concerning equipment and protective systems intended  
for use in potentially explosive atmospheres

and that the following standards have been applied:

EN 50081-1	EN 50082-1	
EN 60079-0:2006	EN 60079-1:2004	EN 60079-7:2003
EN 61241-0:2006	EN 61241-1:2004	

Although the editions of the standards indicated above are no longer harmonised, a review by the Ex Authorized Person against the latest editions listed below identified no significant changes relevant to this equipment. The previously applied standards continue to represent the 'state of the art'.

EN 61000-6-1:2019	EN 61000-6-3:2007 / A1:2011	
EN 60079-0:2018	EN 60079-1:2014	EN 60079-7:2015 / A1:2018
EN 60079-31:2014		

This declaration of conformity is issued under the sole responsibility of the manufacturer

Geldrop, 22 April 2020

Signed



M. Moolenaar  
Managing Director and EX Authorized Person

Artidor Explosion Safety B.V. - Emopad 38, 5663 PB Geldrop - The Netherlands  
Phone: +31 (0)40 78 73 911 - E-mail: sales@artidor.com - www.artidor.com

This document can be subject to change without notice.